

SMART : BPL

ELECTRIC 
COMBI BOILERS CO.
INSTALLATION & SERVICE
GUIDE



FLICKER
HARMONICS
TESTED

CONNECT TO YOUR SMART PHONE



STEP 1

DOWNLOAD THE
MY BOILER APP
TO YOUR SMART
PHONE

STEP 2

CONNECT BOILER TO
YOUR WIFI CONNECTION

1. SETTINGS
2. WIFI

USE DIRECTION
BUTTON TO MAKE
CHARACTER SELECTION

STEP 3

SIGN IN,
AND PAIR
YOUR BOILER TO
YOUR APP

INSTALLATION CHECKLIST

- Install filling loop on inlet (return) pipe.
- Install scale reducer, if the water hardness is medium/high.
- Install central heating filter. (non-bypass filter recommended)
- If the cold water mains pressure to the boiler is more than 2 bar, install pressure PRV.
Set the PRV between 1.5-2.0 bar. This is the working Pressure.
- Ensure to set correct flow rate of boiler after installation .
(Model :C = 6-8Lt/min : BPC/BPL = 10-13Lt/min)
- Ensure to leave clearance as per the boiler model.
- Install dedicated 63A RCD & 50A MCB.
- Ensure you have ventilation for the boiler in the cupboard or cabinet.
- Install a minimum 10mm cable from the consumer box to the boiler via isolator.
- Ensure to use spade connectors provided with the boilers for the 10 or 16mm on the mains connectors on the boiler. (SY & Flexi cable only)
- Ensure to use a relay, if using 240v/Switch Live to T & A connection in the boiler.
- Ensure to purge the system & boiler before running heating & hot water.
- Use surge protection for the boiler to save the appliance from frequent power cuts.
- Due to logistics and handling of the boiler during installation this could lead to minor leaks in the connections. Ensure to tighten the connections or replace with new washers or seals to fix the leak.

SMART: BPL

	H:- 875 W:- 660 D:- 300
--	-------------------------------

DEDICATED

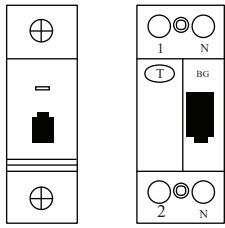

50A MCB 63A RCD

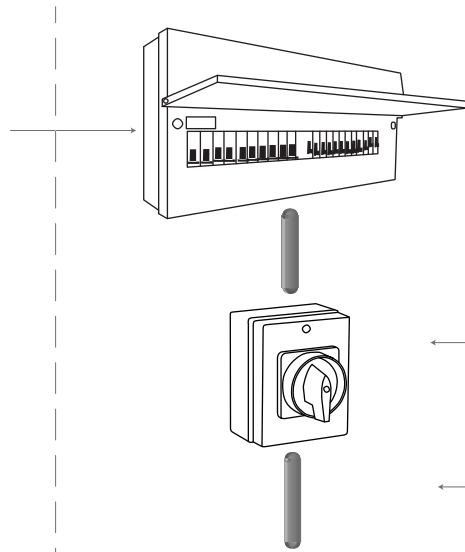

63A ROTARY ISOLATOR SWITCH

10MM CABLE MIN

BOTTOM
300MM CLEARANCE

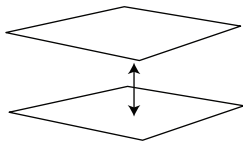

HOT WATER
15MM

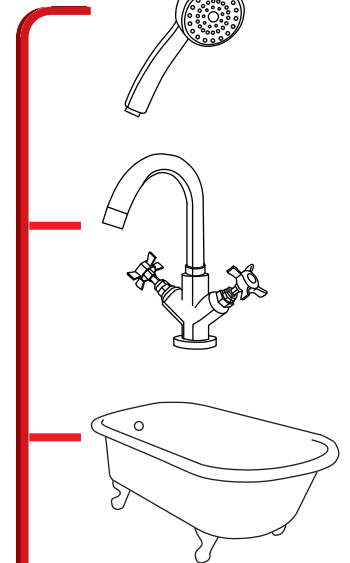

15MM
MAINS COLD WATER
MAX 2 BAR PRESSURE

HEATING RETURN INLET
22MM

HEATING FLOW OUTLET
22MM

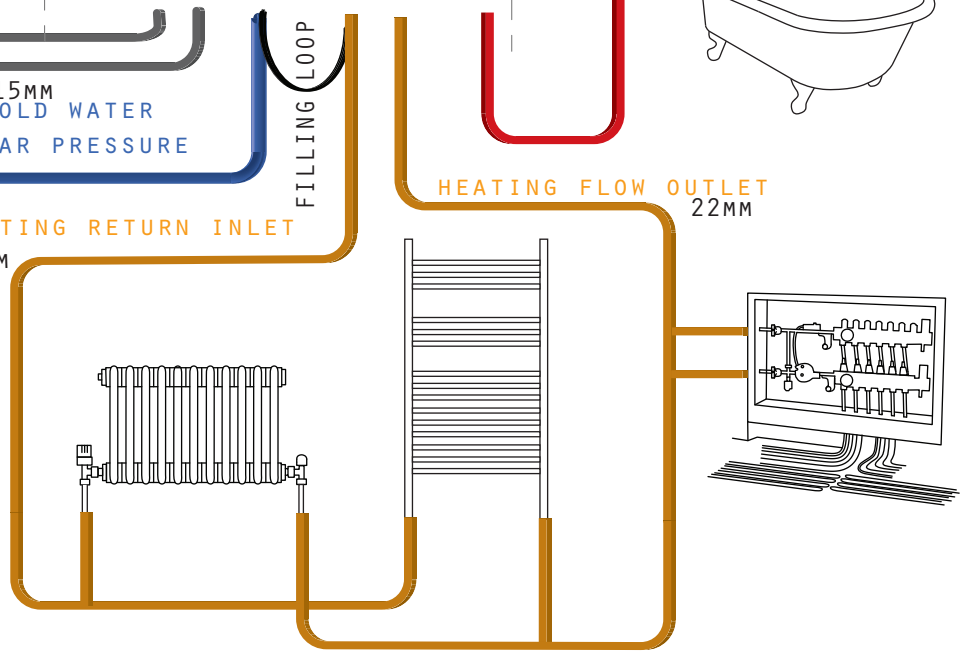

DISCHARGE VALVE
3 BAR
(HEATING)
15MM

DISCHARGE VALVE
6 BAR
(HOT WATER TANK)
15MM

ERROR CODES



FOLLOW OUR YOUTUBE CHANNEL FOR
QUICK FIX TUTORIALS

CHANNEL :- ELECTRIC COMBI BOILERS COMPANY

WARNING & CAUTION

- Do not connect 240v/Switch Live or low voltage on T & A connection in the boiler.
- Do not turn the boiler on without the heating system & hot water tank (applies to BPC & BPL only) filled with water.
 - Do not use cable less than 10mm for the boiler.
 - Do not use isolator switch less than 63A for the boiler.
 - Do not use MCB rated less than 50A for the boiler.
 - Do not share the RCD of the boiler with other MCB's.
- Do not leave the boiler on during power cut. Turn it back on only when the power is back.
- If leaving the boiler in ECO & Summer mode, please ensure to run the boiler central heating for at least 10 minutes once a week to avoid boiler circulating pump stuck issue.

CONTACT

OFFICIAL DISTRIBUTOR FOR UNITED KINGDOM (GB)



ABCOT UK LTD T/A ELECTRIC COMBI BOILERS CO
GREEN ACRES, OAKLEY GREEN RD, WINDSOR
SL4 4QF

02089982024

CONTACT@ELECTRICCOMBIBOILERS.UK

ELECTRIC   
COMBI BOILERS CO.